

# Pressure Vacuum Relief Valve with Flame Arrester

End-of-line, weight loaded, integrated,  
atmospheric deflagration proof

## Model 102



### Product Description

Storagetech™ Model 102 Pressure-Vacuum Relief Valve with Integrated End-of-line Flame Arrester provides total security of mind to operators of storage tanks. The Model 102 ensures protection against damage through over-pressurization, implosion due to vacuum conditions, and prevents any external flame entering the tank. In the closed position the pressure relief pallet and diaphragm assembly is held tightly against a seal to prevent the loss of vapour to atmosphere. As the internal pressure in the tank increases, due to product filling and vapour development,

the pressure in tank increases and in the event that the set pressure of the unit is reached, the diaphragm will open and discharge the gas to atmosphere. The opening set-point is select able from a range between 1 and 28.1 W.C. (2.5 and 70 mbar), and the valve will reseal when the tank returns to a safe pressure. The vacuum pallet and diaphragm assembly is similarly maintained in the closed position.

As the internal pressure in the tank reduces, due to emptying, the balance between the tank pressure and the external atmospheric pressure changes, and when the set pressure of the unit is reached, the diaphragm opens to admit air and rebal-ance the internal pressure.



StorageTech provides the high quality and reliable solutions for your needs with 40 years of experience.

Your investments will be much safer with Storagetech™ Flame Arrester solutions, which are completely produced in accordance with international

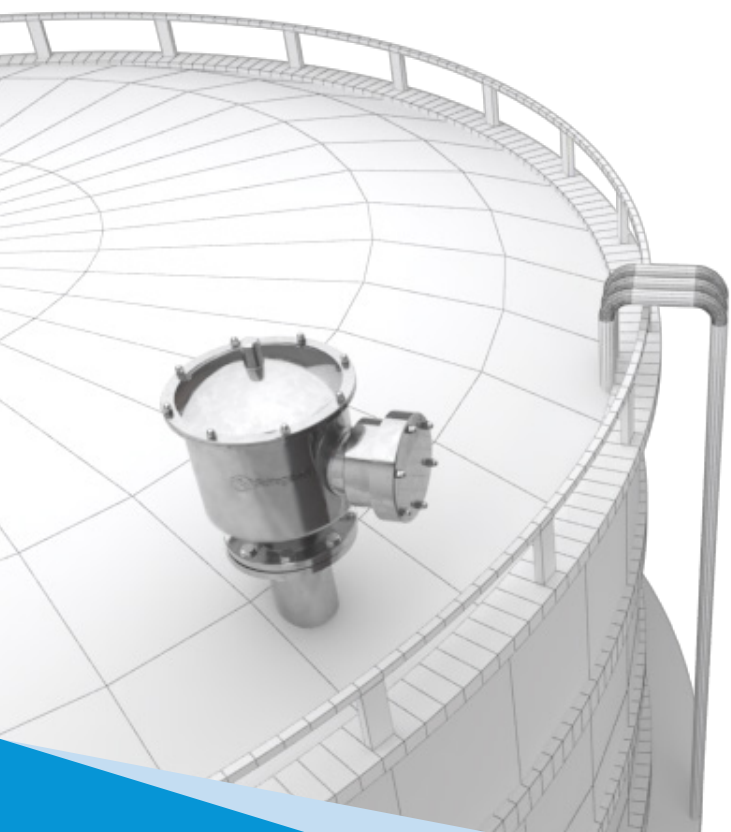

### Setting Range

Pressure	Weight-loaded 2.5 mbar to 70 mbar
Ambient temp.	-20 C to +60 C

## Product Description

Storagetech's Model 330 Pressure Vacuum Relief Valve with Flame Arrestor provides protection to bulk storage tanks and vessels from over and under-pressurization. The valves are mounted on the tank roof flange or a vent pipe from the vapour space. In the closed position the pressure relief pallet and diaphragm assembly are held tightly against a seal to prevent the loss of vapour to the atmosphere.

As the internal pressure in the tank increases, due to product filling and vapour development, the pressure in the tank increases, and in the event that the set pressure of the unit is reached, the diaphragm will open and discharge the gas into the atmosphere. The opening set-point is select able from a range between +61 mbar and +1000 mbar (+24 inch W.C. and 400 inch W.C.), and the valve will reseal when the tank returns to a safe pressure.

An in-line flame arrestor combination provides extra safety and avoids flame entrance inside the storage tank or pipe through valve openings. The flame arrestor can be unbolted and removed easily for maintenance purposes without affecting the pressure vacuum relief valve function.



\* When removing, cleaning, and replacing element banks, it is vital that the installation, operation, and maintenance instructions (IOMs) provided by the manufacturer are strictly adhered to. norms.

## Design & Manufacturing Specifications



ISO 16852:2008 - Flame Arresters, Performance requirements, test methods and limits of use.

API RP 2210 -Flame Arrestors for Vents of Tanks Storing Petroleum Product.

The size of the vent should be calculated in accordance with API Standard 2000 (ISO 28300) - Venting Atmospheric and Low-Pressure Storage Tanks or other international standards.

The integrity of the seal is tested for leakage in accordance with API Standard 2521 - Use of Pressure-Vacuum Vent Valves for Atmospheric Loss.

## Construction

Sizes	2" to 12"
Flanges	ANSI 150# RF, DIN PN16
Body	Carbon steel, stainless steel, or aluminium
Cap	Carbon steel, stainless steel, or aluminium
Cover	Carbon steel, stainless steel, or aluminium
Seals	Viton and Klingrit
Pallet	Stainless steel AISI 304
Paint Finish	1- Powder Coating, Colour RAL 9006 2- Epoxy Paint, Colour RAL 9006 3- Customer Specification

## End-Of-Line Flame Arrester, Deflagration

This deflagration flame arrester is suitable for quenching sub-sonic flames and should be located at the end of a pipeline or exit from a vessel.

It should be installed in the horizontal plane and is not for use with pressure relief valves or pressure-vacuum relief valves. A weather hood and screen protect the vent and restricts dust, wind, rain, or insects from entering and degrading the efficacy of the product.

## Standard Compliance

In-Line Deflagration Flame Arresters has been type-tested to EN ISO 16852 and approved according to ATEX Directive 2014/34/EU.



## Key Features

- StorageTech™ PW Model 102 internal materials are AISI 304 or 316 stainless steel.
- Easy to clean internal materials.
- Easy to install. You do not need a special tool or experience to install the StorageTech Flame Arrester Model 102.
- StorageTech™ PVV Model 102 comes with the paint color you choose.
- Standard manufacturing comes with ANSI 150# flange; however other flange types are available on request.
- Protection cap is manufactured from aluminum material.

## Product Benefits

---

The area of each passage determines level of protection that the element provides. StorageTech TM Model 102 Inline Deflagration Flame Arrester has a Maximum Experimental Safe Gap as per standard, and is suitable for gas groups IIB and IIA.

Flame arresters are usually designed for use at ambient temperature and pressure. Please consult StorageTech experienced and trained engineers for advice if other conditions are encountered. Higher temperatures and pressures put increased load on the flame arrester and testing under actual or simulated conditions may be required.

Regular inspection and maintenance of flame arresters is essential. If a flashback is known or believed to have occurred then the arrester should be inspected for damage. Small cells or components of the flame arrester are prone to dirt collection and clogging, leading to increased pressure drop. Damaged or dirty elements should be replaced. It is usually possible to clean the element for reuse. When properly maintained, a flame arrester can provide many years of service.

## Unconfined Deflagration

---

Unconfined deflagration is caused by the ignition of a flammable gas outside a container or equipment. For example, vent gas from a gasoline tank can create a cloud of flammable vapor around it. A lit cigarette, static electricity or lightning can ignite this vapor and the resulting flame can return to the tank.

## Confined Deflagration

When a flammable mixture in a pipeline is ignited, the flame front initially travels along the pipe at subsonic speeds, a phenomenon called confined deflagration. For example, methane gas produced in underground coal mines is transported to the surface through a pipe and burned in a boiler.

However, a malfunction in the boiler or pumping system can ignite the gas in the pipe and the flame can travel along the pipe and explode the gas underground.



## Technical Drawing

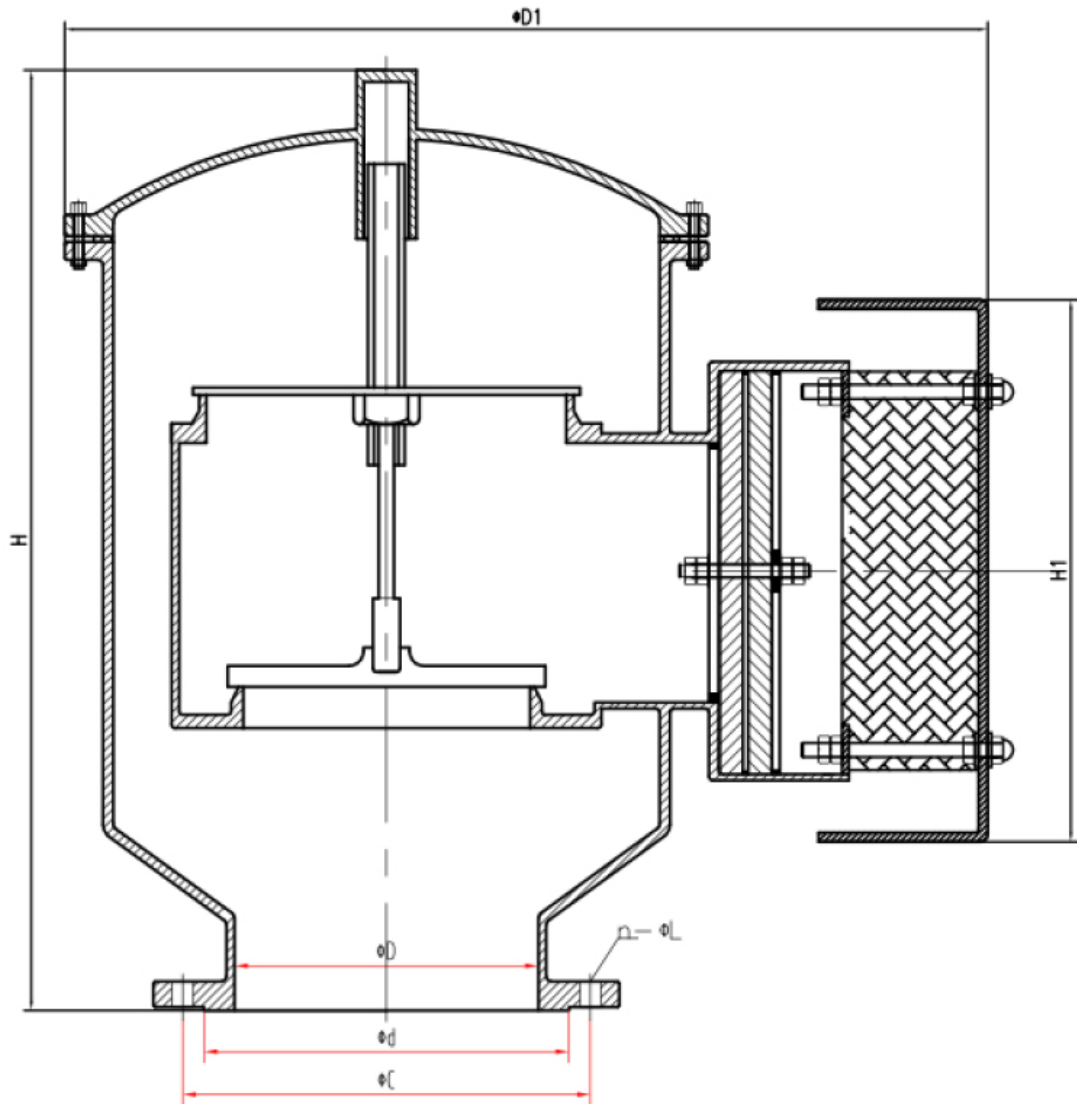

### Dimensions

ØD	Ød	ØC	ØL	n	ØD1	H	H1
2"	92	120,5	18	4	310	195	168
3"	127	152,5	18	4	360	240	205
4"	157,5	190,5	18	4	380	265	230
6"	216	241,5	22	8	450	285	275
8"	270	298,5	22	8	505	320	320
10"	324	362	26	12	565	380	350
12"	381	432	26	12	645	450	435

<b>A</b>	•Element Diameter
A-H	•Element Height
<b>B</b>	•Element Housing Diameter
B-H	•Element Housing Height
<b>C</b>	•Element Holder Diameter
C-H	•Element Holder Height
<b>D</b>	•Spacer Diameter
D-H	•Spacer Height

MODEL	IIA DEFLAGRATION - MODEL 102									
	2"	3"	4"	6"	8"	10"	12"	14"	16"	
<b>A</b>	100	150	200	250	300	500	600	700	800	
A-H	10	10	10	10	10	15	15	15	15	
<b>B</b>	100	200	250	280	350	550	700	800	900	
B-H	90	90	90	100	100	200	200	200	200	
<b>C</b>	100	150	200	250	300	500	600	700	800	
C-H	10	10	10	20	20	20	20	20	20	
<b>D</b>	100	150	200	250	300	500	600	700	800	
D-H	6	6	6	6	6	6	6	6	6	

MODEL	IIB DEFLAGRATION - MODEL 102							
	2"	3"	4"	6"	8"	10"	12"	
<b>A</b>	100	200	250	300	400	500	600	
A-H	30	30	30	30	30	30	30	
<b>B</b>	150	250	300	350	450	550	700	
B-H	131	151	151	212	232	232	232	
<b>C</b>	100	200	250	300	400	500	600	
C-H	18	28	28	28	38	38	38	

## Flow Capacity Tables

### Pressure Drops (mbar)

Gas Group	Element	Pipe Size	Flow in Nm <sup>3</sup> /h Air																		
			5	10	15	20	30	40	50	60	70	80	90	100	150	200	300	400	500		
IIA	100/10/54	DN50	2"	<0.5	<0.5	<0.5	<0.5	<0.5	<0.5	<0.5	<0.5	<0.5	<0.5	<0.5	0.7	0.9	2.2	3.8	8.8	15.6	28.2
	150/10/54	DN80	3"	<0.5	<0.5	<0.5	<0.5	<0.5	<0.5	<0.5	<0.5	<0.5	<0.5	<0.5	<0.5	<0.5	0.5	0.8	1.7	2.6	4.8
	200/10/54	DN100	4"	<0.5	<0.5	<0.5	<0.5	<0.5	<0.5	<0.5	<0.5	<0.5	<0.5	<0.5	<0.5	<0.5	<0.5	<0.5	<0.5	0.7	1.3
	250/10/54	DN150	6"	<0.5	<0.5	<0.5	<0.5	<0.5	<0.5	<0.5	<0.5	<0.5	<0.5	<0.5	<0.5	<0.5	<0.5	0.5	<0.5	<0.5	<0.5
	300/10/54	DN200	8"	<0.5	<0.5	<0.5	<0.5	<0.5	<0.5	<0.5	<0.5	<0.5	<0.5	<0.5	<0.5	<0.5	<0.5	<0.5	<0.5	<0.5	<0.5
	500/15/54	DN250	10"	<0.5	<0.5	<0.5	<0.5	<0.5	<0.5	<0.5	<0.5	<0.5	<0.5	<0.5	<0.5	<0.5	<0.5	<0.5	<0.5	<0.5	<0.5
	600/15/54	DN300	12"	<0.5	<0.5	<0.5	<0.5	<0.5	<0.5	<0.5	<0.5	<0.5	<0.5	<0.5	<0.5	<0.5	<0.5	<0.5	<0.5	<0.5	<0.5
IIB	100/30/35	DN50	2"	<0.5	<0.5	<0.5	<0.5	<0.5	<0.5	<0.5	0.7	1.1	1.4	1.8	2.3	5.1	9.2	20.3	36.8	58.2	
	200/30/35	DN80	3"	<0.5	<0.5	<0.5	<0.5	<0.5	<0.5	<0.5	<0.5	<0.5	<0.5	<0.5	<0.5	0.5	1.1	2.8	5.2	7.4	
	250/30/35	DN100	4"	<0.5	<0.5	<0.5	<0.5	<0.5	<0.5	<0.5	<0.5	<0.5	<0.5	<0.5	<0.5	<0.5	<0.5	0.9	1.9	3.2	
	300/30/35	DN150	6"	<0.5	<0.5	<0.5	<0.5	<0.5	<0.5	<0.5	<0.5	<0.5	<0.5	<0.5	<0.5	<0.5	<0.5	<0.5	<0.5	0.7	1.2
	400/30/35	DN200	8"	<0.5	<0.5	<0.5	<0.5	<0.5	<0.5	<0.5	<0.5	<0.5	<0.5	<0.5	<0.5	<0.5	<0.5	<0.5	<0.5	<0.5	<0.5
	500/30/35	DN250	10"	<0.5	<0.5	<0.5	<0.5	<0.5	<0.5	<0.5	<0.5	<0.5	<0.5	<0.5	<0.5	<0.5	<0.5	<0.5	<0.5	<0.5	<0.5
	600/30/35	DN300	12"	<0.5	<0.5	<0.5	<0.5	<0.5	<0.5	<0.5	<0.5	<0.5	<0.5	<0.5	<0.5	<0.5	<0.5	<0.5	<0.5	<0.5	<0.5

Gas Group	Element	Pipe Size	Flow in Nm <sup>3</sup> /h Air																	
			600	700	800	900	1000	2000	3000	4000	5000	6000	7000	8000	9000	10000	12000	16000	18000	
IIA	100/10/54	DN50	2"	39.3	51.2	68.5	85.2	106.8												
	150/10/54	DN80	3"	7.1	9.2	12.2	15.9	19.2	79.3	189.4										
	200/10/54	DN100	4"	1.8	2.9	3.4	4.1	5.2	20.9	48.3	86.5	139.2								
	250/10/54	DN150	6"	0.7	0.9	1.2	1.5	2.2	7.1	16.8	30.1	45.8	76.9	93.2	123.5	157.1	197.3			
	300/10/54	DN200	8"	<0.5	<0.5	0.5	0.8	1.1	3.9	9.2	15.5	25.1	36.3	49.7	65.2	83.3	103.5	151.4		
	500/15/54	DN250	10"	<0.5	<0.5	<0.5	<0.5	<0.5	0.7	1.9	2.7	5.3	7.4	9.2	12.5	15.3	19.2	27.8	49.4	63.8
	600/15/54	DN300	12"	<0.5	<0.5	<0.5	<0.5	<0.5	<0.5	0.8	1.4	2.3	3.4	4.9	6.2	7.1	8.7	13.2	24.4	30.2
IIB	100/10/54	DN50	2"	83.7	115.3	151.5	195.4	245.6												
	150/10/54	DN80	3"	10.1	14.2	18.6	23.2	29.5	118.2											
	200/10/54	DN100	4"	3.9	5.1	7.2	8.8	11.3	45.5	103.2	188.4									
	300/30/35	DN150	6"	1.8	2.3	3.3	4.1	5.4	20.1	45.2	80.3	128.5	187.6							
	400/30/35	DN200	8"	<0.5	0.7	1.3	1.6	2.3	8.2	17.4	30.8	49.3	71.3	97.6	128.2	165.3	206.4			
	500/30/35	DN250	10"	<0.5	<0.5	<0.5	<0.5	0.6	2.8	6.2	11.3	17.5	24.3	32.7	42.6	55.5	68.1	99.3	181.9	234.2
	600/30/35	DN300	12"	<0.5	<0.5	<0.5	<0.5	<0.5	1.1	3.2	4.7	8.2	11.3	15.4	20.3	25.5	31.1	45.2	81.6	104.3

## Flow Capacity Curves

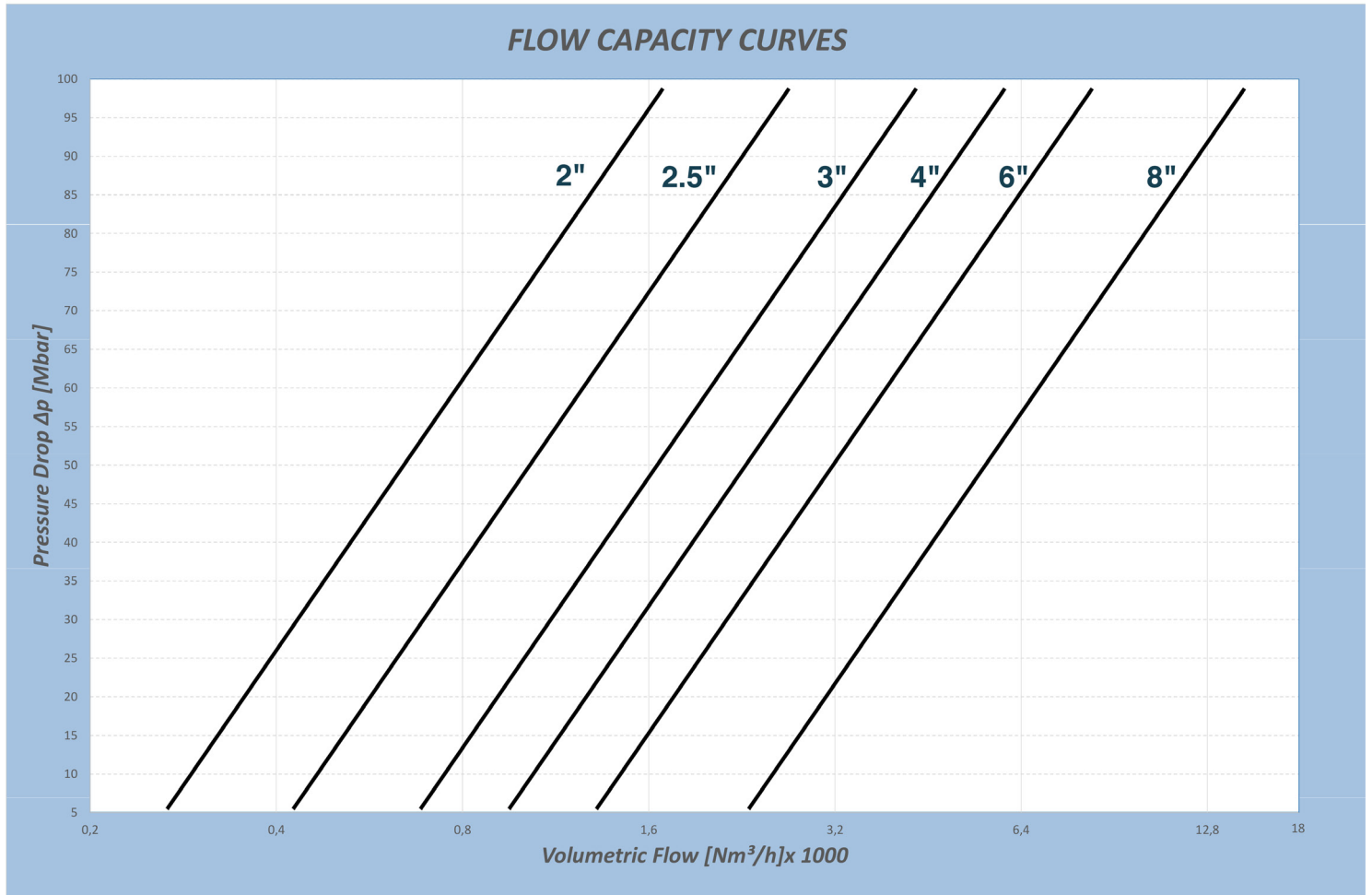

# Product Recommendations



**Biogas Safety Selector Valve (SSV)**

Model: 250

The Storagetech Biogas Safety Selector Valve (SSV) is an advanced, cost-effective alternative to traditional three-way plug valves, designed for seamless operation in biogas systems. It enables smooth switching between Pressure and Vacuum Relief Valves (PVRs) with Flame Arrestors, ensuring uninterrupted operation during maintenance.



**Pressure Vacuum Relief Valve With Flame Arrestor**

End-Of-Line,  
Weight Loaded,  
Combination,  
Atmospheric Deflagration  
Proof

Model: 330

Storagetech™'s Model 330 Pressure Vacuum Relief Valve with Flame Arrestor provides protection to bulk storage tanks and vessels from over and under pressurization.

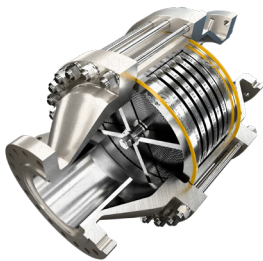

**Flame Arrestor**

Vertical,  
In-Line,  
Detonation

Model: 320

Storagetech™'s Model 320 In-line Detonation Flame Arrestor (also called flame arrestor or fire arrestor) is designed for installation in gas pipelines. Detonation occurs when a flame travelling through the pipeline reaches supersonic velocities, usually as a result of the pipeline configuration or pipeline surface roughness. Changes in gas density and pressure causes the flame velocity to metamorphose from subsonic to supersonic.



**Flame Arrestor**

Horizontal,  
In-Line,  
Detonation

Model: 321

Storagetech™'s Model 321 In-line Detonation Flame Arrestor (also called flame arrestor or fire arrestor) is designed for installation in gas pipelines. Detonation occurs when a flame travelling through the pipeline reaches supersonic velocities, usually as a result of the pipeline configuration or pipeline surface roughness. Changes in gas density and pressure causes the flame velocity to metamorphose from subsonic to supersonic.

## Äger GmbH

Germany Head Office + R&D + Sales  
Herzogspitalstraße 24  
Munich 80331  
Germany  
+49 (0) 89 1250 15240  
www.aager.de  
sales@aager.de

Turkey Head Office + Sales  
Ağaoğlu My Office 212  
No: 3 B Blok /175  
PK 34218 Güneşli – Bağcılar  
Istanbul / Turkey  
+90 212 485 40 07  
+90 212 485 40 42  
sales@aager.de  
sales@storagetech.de

Turkey Factory + Engineering + R&D + Sales  
Mersin Tarsus OSB.13.CD.NO:7  
PK: 33540 Mersin, Turkey  
+90 324 676 44 04  
+90 324 676 44 03  
sales@aager.de  
sales@storagetech.de

UAE Sales + Warehouse  
Jumeirah Lake Towers, X2 Tower 1906  
P.O. Box: 123661 Dubai, UAE  
+971 4 450 8051  
+971 4 450 8041  
sales@storagetech.de

KSA Sales + Warehouse  
Q1-14, The Business Quarter,  
King Faisal Road,  
Al Khalidiyyah Al Janubiyah,  
Dammam, KSA  
+966138163471  
sales@storagetech.de



### data sheet series

PVRV with FA - E.O.L., W.L.,  
integ., atmospheric def. proof

Revision No: 02  
ST-DS-PV.FA.DFI-04.25/V2  
storagetech.de



April 2025

