

## FLOATING ROOF SEALING SYSTEMS

### Features

- Lower Emission Rates
- 100% Aromatics Resistivity
- No Welding at Site
- Easy Maintenance
- Less Fatigue Case with Hardened Materials
- All Fasteners and Washers are Stainless Steel
- Full Conformity acc. to Std AP-42 and API 650 App. H.
- Easy Installation and No Need for Special Equipment
- Protect Environment from Toxic Gasses
- W/ Teflon Fabric, Shunts, Shoes
  - Galvanised(1.5mm in thk.)
  - Stainless Steel (1.2mm in thk.)

### Additional

- Wax scraper
- Foam Dam
- Secondary Vapor Barrier W/ teflon Fabric
- Anti Hang-up Device



### Primary Shoe Plate Seal

ERGIL StorageTech™ Primary Mechanical shoe seal system has been specified according to the type of Storage tank and liquid stored. Mostly used sealing systems are liquid mounted mechanical shoe seals. Choosing the effective type of sealing system is completely depends on stored products and emission requirements. Corrosion resistivity of the sealing material is directly affected by the liquid stored. Sealing material has to be chosen according to the chemical resistance compatibility. At that moment, specifying better quality material with low cost in a balance is the most important issue regarding be used the sealing system.

### Benefits

Wrongly those products are having a highly problematic future maintenance issues which would be resulted in the loss of valuable sources and especially time. There need to be certain combinations of seal material as well as auxiliary products can provide a better solution for each specific situation. Mechanical shoe seal materials have to be determined carefully in the case of continuously processes, minimum maintenance requirements as well as stored corrosive media scenarios. As a result, it is a priority to keep the total weight as light as possible because higher the quality and strength are increasing the material prices. ERGIL StorageTech™ shall provide the best application in a best price/performance ratio for our Valuable Clients. The metallic seal is characterized by a metallic sheet (the "shoe") that is held against the vertical tank wall.

## Design Features

Each seal is customized to fit the tank to ensure maximum performance, long life, and safe operation. Primary seals include a variety of configuration and component options. The shoe is connected by braces to the floating deck and is held tightly against the wall by springs or weighted levers. A flexible coated fabric (made of Teflon) is suspended from the shoe seal to the floating deck to form a vapor barrier over the annular space between the deck and the primary seal. ERGIL StorageTech™ Liquid mounted Primary shoe seals can be categorized as PANTOGRAPH and SCISSOR type seals. The most important issue that affects the performance of the sealing system is that the load which is applied on to the shoe seals needs to balance and this force covers all openings through the rim. Mechanical seal systems are restricted to the lined storage tanks for not damaging the cladding material.

## PANTOGRAPH TYPE

Thanks to the pressure applied by the weights, the pressure on the top and bottom of the mechanical seal is maximized. Because of its weighted construction, Because the materials used are thinner than Carbon steel and Aluminum as well as the usage of additional weight is not required, the system minimizes product escape with the effective pressure provided by the springs, unlike the weighted system. Effective seal performance can cover openings up to 200 mm. and it can work with  $\pm 100$  mm tolerance.

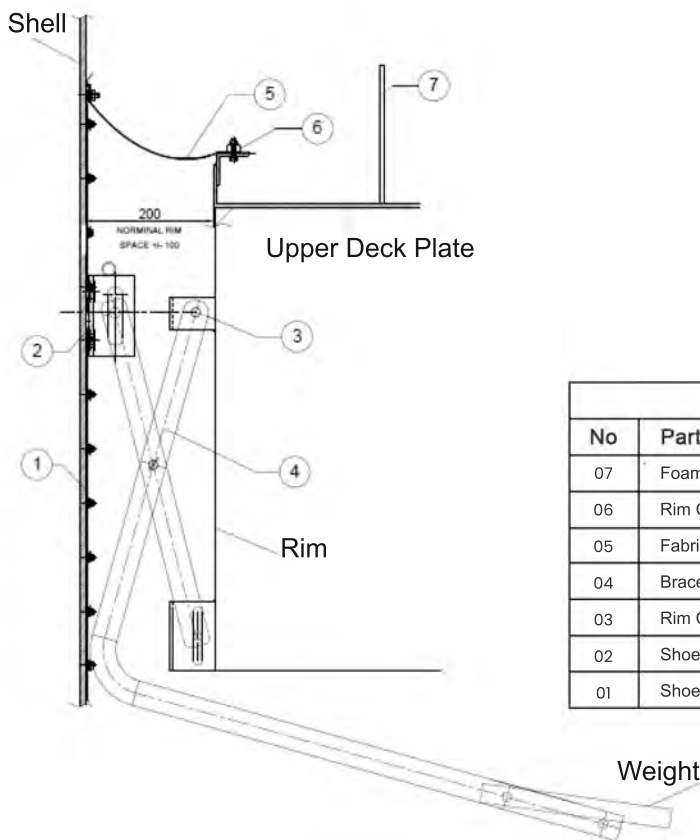

PART LIST			
No	Part Name	Material	Remarks
07	Foam Dam, Thk.3mm	Optional	---
06	Rim Clamp	A653 / G90	---
05	Fabric	Teflon	---
04	Braces	ASTM SA 240 gr. 304/316 S235 JR (G)	1/4 Hardened
03	Rim Clip	ASTM SA 240 gr. 304/316 S235 JR (G)	1/4 Hardened
02	Shoe Bracket	ASTM SA 240 gr. 304/316 S235 JR (G)	1/4 Hardened
01	Shoe Plate	ASTM SA 240 gr. 304/316 S235 JR (G)	1/4 Hardened

## SCISSOR TYPE

The most important case in the usage of this type sealing is to increase the material strength by reducing the weight and to ensure the sealing of, especially light and corrosive storage products.

ERGIL StorageTech™ recommends the use of Scissor type sealing in the lie of pantograph seal in order to balance price/performance ratio for extreme corrosive volatile or light storage products. Effective seal performance can cover opening up to 200 mm. And it can work out with  $\pm 100$  mm tolerance.

Thanks to its superior spring system, it successfully meets 300 mm rim width and works effectively maximum  $\pm 100$  mm tolerance in range.

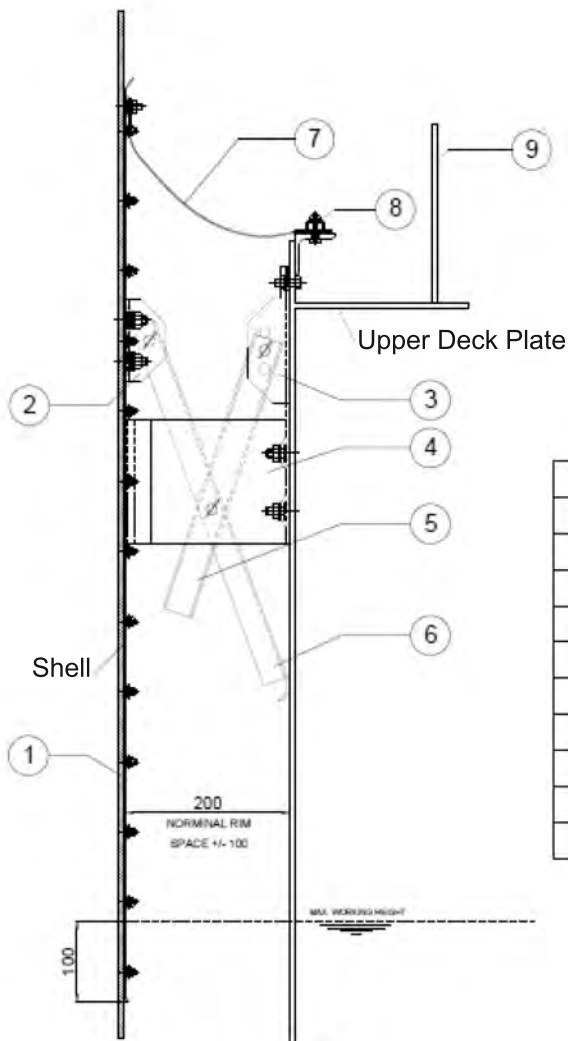

PART LIST			
No	Part Name	Material	Remarks
09	Foam Dam, Thk.3mm	Optional	---
08	Rim Clamp	A653 / G90	---
07	Fabric	Teflon	---
06	Spacer Plate Scissor	ASTM SA 240 gr. 304/316 S235 JR (G)	1/4 Hardened
05	Rim Scissor	ASTM SA 240 gr. 304/316 S235 JR (G)	1/4 Hardened
04	Spring	ASTM SA 240 gr. 304/316 S235 JR (G)	1/4 Hardened
03	Rim Clip	ASTM SA 240 gr. 304/316 S235 JR (G)	1/4 Hardened
02	Shoe Bracket	ASTM SA 240 gr. 304/316 S235 JR (G)	1/4 Hardened
01	Shoe Plate	ASTM SA 240 gr. 304/316 S235 JR (G)	1/4 Hardened

## FLOATING ROOF SEALING SYSTEMS

### Features

- Lower Emission Rates
- 100% Aromatics Resistivity
- No Welding at Site
- Easy Maintenance
- Full Conformity acc. to Std AP-42 and API 650 App. H.
- Easy Installation and No Need for Special Equipment
- Protect Environment from Toxic Gasses
- W/ Teflon Fabric



### Wiper Seals on Spring Plates

Double layer wiper system allows for less tip pressure and provides longer service life with Teflon fabrics. Especially for blocking further emission rates, it is mostly to be used on the mechanical shoe seals covering the entire primary seal. A secondary seal on an external or internal floating roof consists of a continuous seal mounted on the rim of the floating roof and bridge the gap between the roof and tank wall.

### Benefits

A rim-mounted double layer seal installed on primary seal provides a blockage for volatile organic compound (VOC) through emission that escapes from the small vapor space by the primary seal as well as through any openings or small gaps in the sealed envelope of a metallic shoe sea. Because of the pressure applied on seal by the compression plate, double layer wiper seal cover all of the gaps caused by the shell plate defects and tolerance issues. In the case of the certain requirement for corrosion resistivity and shell surface issues, double layer wiper seal usage can be determined as the primary seal in lieu of wiper seal blade. As a secondary seal, it can be utilized in conjunction with a weather shield with including Teflon envelope for the external floating roof to bridge the tank wall by preventing external dust, dirt, rain, etc.

## Design Features

The Spring tension provided by the features of the compression plate is designed to provide the loading continuously under all conditions. Plates are produced from spring steel which is hardened material. The most important feature of this product is that the spring tension coming from the plates can be reflected directly to the seal's tip as a pressure force. This design has been developed to minimize emission leakage originating from any gap or openings. The seal material has higher volatile corrosion resistance and can be produced from several different materials according to the stored content. The choice of the sealing products can be determined based on the emission calculations performed and the corrosive media requirements. Accordingly, seal system would be determined as double layer wiper lip seal or wiper seal, which are more economical. It can be used in combination with alloyed auxiliary steel parts to increase the corrosion resistance of compression plates according to their process requirements. In the case of overflow, sealing can be equipped with anti-hang up systems which can pass to operation position without damaging any system for external floating roof applications.

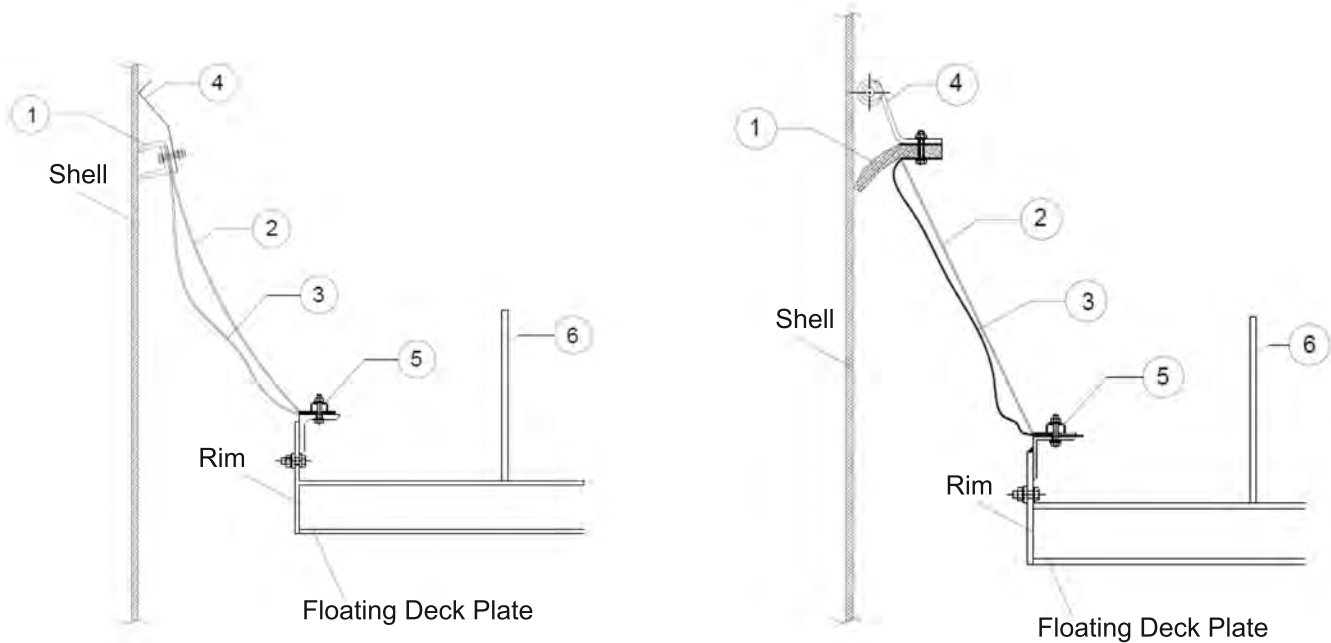

PART LIST			
No	Part Name	Material	Remarks
06	Foam Dam, Thk.3mm	Optional	---
05	Rim Clamp,Thk.3mm, C30x900 Lg	A653 / G90	---
04	Ground Shunt, Thk.05mm	ASTM SA 240 gr. 304	---
03	Fabric / Teflon Envelope	Teflon	---
02	Compression Plate	A653 / G90	1/4 Hardened
01	Double Wiper / Wiper Seal	Nitril / Polyethylene	---

## Double Layer Wiper Seal

The most important issue usage of this type sealing is to increase the compensation capacity of the gaps or openings due to above mentioned reasons. Thanks to its superior spring system, it successfully meets 200 mm rim width and works effectively maximum  $\pm 100$  mm tolerance in range. Further gaps can be tolerated as per special design requirements. The system is grounded by the shunt parts to prevent electrical arc that can occur due to static electricity on entire system. A special roller system which protects the balance of the deck can be added as a optional, in addition to anti rotation system in the case of the vortex situations which can occur due to high flow rates during filling of the tank or the shifting of the deck through shell originating from high wind speeds for the external floating roof.

The system is grounded by the shunt parts to prevent electrical arc that can occur due to static electricity on entire system.

A special roller system which protects the balance of the deck can be added as a optional, in addition to anti rotation system in the case of the vortex situations which can occur due to high flow rates during filling of the tank or the shifting of the deck through shell originating from high wind speeds for the external floating roof.

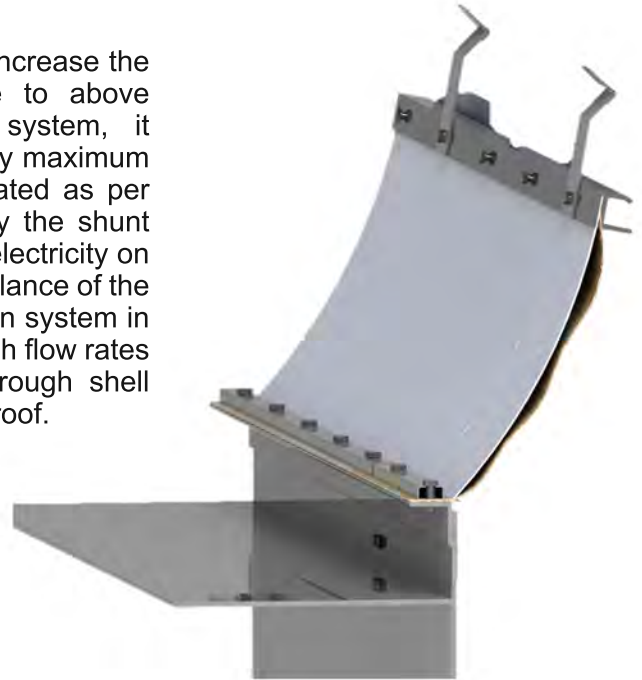

### ACCESORIES

Component By	Materials / Items		
Body Material	Aluminium	Carbon Steel(G)	Stainless Steel
Seal Material	Polyethylene	Nitril	
Hardware Material	Aluminium	Stainless Steel	
Optional	Roller	Anti Hang-up	Foam Dam

### COMMONLY USED MATERIALS

Liquid Type	Body Materials			Seal Materials	
Fuel Oils	Carbon Steel(G)	Carbon Steel(G)	Carbon Steel(G)	LDPE	Nitril
Gasoline (High Aromatic)	Stainless Steel	Stainless Steel	Stainless Steel	LDPE	Nitril
Gasoline (Leaded/Unleaded)	Carbon Steel(G)	Carbon Steel(G)	Carbon Steel(G)	Nitril	
Jet Fuel (JP#,JP4,JP5)	Carbon Steel(G)	Carbon Steel(G)	Carbon Steel(G)	Nitril	
Kerosene	Aluminium	Aluminium	Aluminium	Nitril	
Naptha	Aluminium	Aluminium	Aluminium	LDPE	Nitril

## FLOATING ROOF SEALING SYSTEMS

### Features

- Lower Emission Rates
- 100% Aromatics Resistivity
- No Welding at Site
- Easy Maintenance
- Full Conformity acc. to Std API 650 App. H. & AP-42
- Easy Installation and No Need for Special Equipment
- Protect Environment from Toxic Gasses

### Optionals

- Foam Dam
- Hardware Materials



### Internal Floating Roof Wiper Seals

ERGIL StorageTech™ Wiper Seal is one of the most economical and effective types of rim seal available in the market with tremendous gap sealing ability, maintenance-free operation and long life service. ERGIL StorageTech™ Wiper Seal is designed to fit specific tank round anomalies and allows for in-service installation. Secondary Wiper Seal has proven longevity and it is made of high-quality, corrosion-resistant, inert materials.

Wiper seals are commonly used as primary rim seals for internal floating roof tanks. Wiper seals generally consist of a continuous annular blade of flexible material fastened to a mounting bracket on the deck perimeter that spans the annular rim space and contacts the tank shell. The mounting is such that the blade is flexed, and its elasticity provides a sealing pressure against the tank shell. Polyethylene is the material that commonly used in the Oil & Gas Industry. There are several different types of sealing materials that need to be chosen carefully as per the stored liquid. Due to corrosion resistivity of the content, the material can be easily damaged by the wrongly chosen goods.

Such seals are vapor-mounted; a vapor space exists between the liquid stock and the bottom of the seal. For emission control, it is important that the mounting be vapor-tight, that the seal extends around the circumference of the roof, and that the blade is in substantial contact with the tank shell.



## Design & Features

A peripheral seal positioned as indicated, it does not normally contact the surface of the stored liquid. Vapor-mounted peripheral flexible-wiper seals which rim seal utilizing a blade or tip of a flexible material with or without a reinforcing cloth or mesh. All radial joints in the blade are joined by using seal chemicals. Seal Material elasticity is designed to cover all of the gaps and spacings perfectly. Maintenance can be performed easily and quickly by removing shown bolts. Seal Blades has the capability of bridge 200 mm rim to shell distance and it is able to work in tolerance of 100 mm.

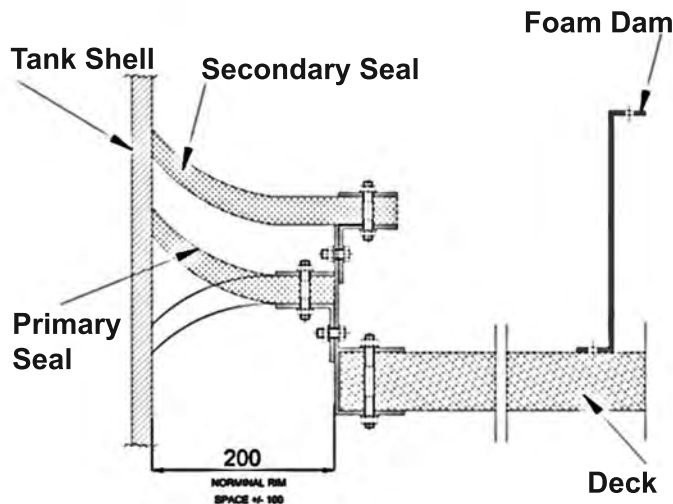
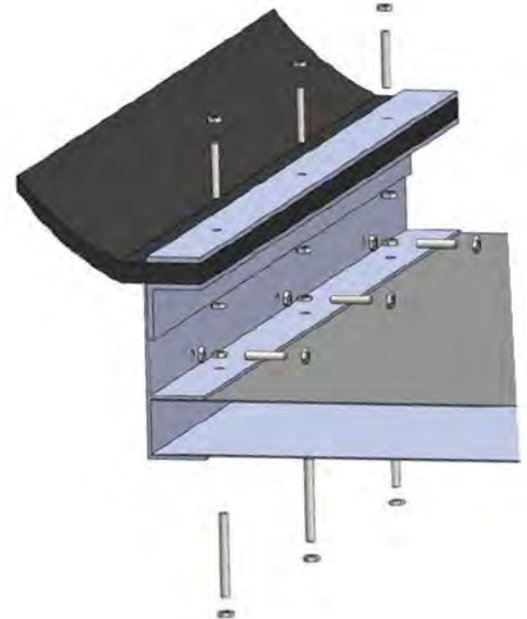

### **Secondary Seal Usage**

Secondary seals may be used to provide some additional evaporative loss control over that achieved by the primary seal. The secondary seal is mounted to an extended vertical rim plate, above the primary seal.

## Recommendation

According to the provided roof design, using a secondary seal can further limit the operating capacity of a tank because of the need to maintain contact with the tank shell or keep the seal from interfering with fixed-roof rafters of the storage tank when the tank is filled. For that reason, performing design checks before manufacturing is obligatory as per tank design. It is very critical that the comparison of estimated average rim seal losses as a calculation basis and decide whether a secondary vapor barrier is mandatory.

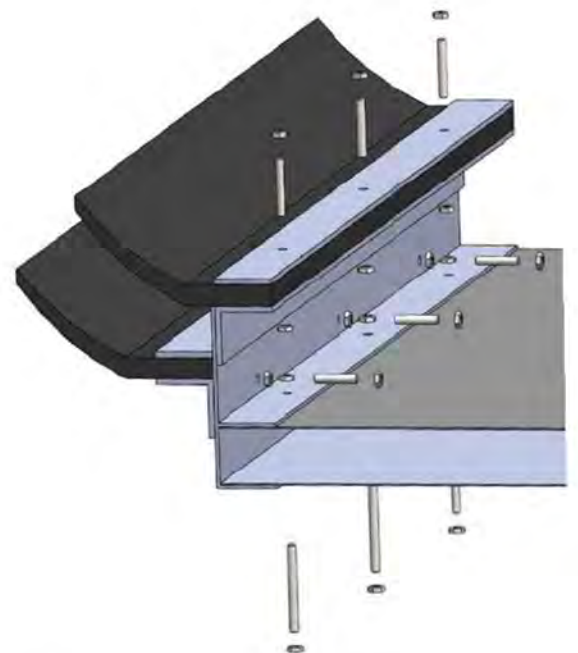



## Chemical Compatability of Wiper Seals

Chemical compatibility refer to material resistance to corosion when contact with a chemicals. Choosing true material is the most important part of the sealent life and operation efficiency. Following tabulated datas are assigned to corosion effect of mostly preferred liquids & seal materials that being in contact liquid and vapor phase.

### SEAL MATERIAL

Liquid Type	LDPE		Nitril	
	Liquid / Vapor		Liquid / Vapor	
Acetone	B	A	D	C
Acrylonitrile	A	A	D	D
Aromatic Hydracorabons	C	B	D	C
Benzene	C	B	D	C
Cyclohexane	B	A	B	A
Diesel Fuel	C	A	A	A
Diesel Oil (2D/3D/4D/5D)	A	A	A	A
Ethyl Alcohol	B	A	D	C
Ethylene Glycol	A	A	A	A
Fuel Oils	B	A	A	A
Fuel(1/2/3/5A/5B/6)	B	A	B	A
Gasoline (High Aromatic)	A	A	A	A
Gasoline (Leaded/Unleaded)	C	B	A	A
Heptane	B	A	A	A
Hexane	D	C	A	A
Hydraulic Oils	C	B	A	A
Jet Fuels (JP3/JP4/JP5)	D	D	A	A
Kerosene	C	B	A	A
Lubricants	D	C	A	A
Methyl Acetate	B	A	D	D
Methyl Alcohol	A	A	A	A
Naphtha	A	A	A	A
Pentane	D	D	A	A
Phosphoric Acid (Crude)	B	A	D	C
Sulfuric Acid (Strong)	B	A	C	C
Xylene	B	A	D	C

#### Rattings - Chemical Effect

A- Excellent

B- Good : Minor Effect, Slight corrosion, or discoloration.

C- Fair : Moderate Effect, not reccommended for continuous use. Softening or loss of strenght, and swelling may occur.

D- Severe Effect : Not recommended for any use.