

# Flame Arrester

## Horizontal, in-line, deflagration



### Model 301

## Product Description

StorageTech™ Model Number 301 Flame Arrester is a safety device that has a flame barrier with a large number of defined passage gaps, whose gap cross section is set with regard to the properties of the flowing gas, is cooled effectively and secured against a flame flashback in the case of continuous combustion. They are typically mounted to a flange or pipe, which connects the vapor space of a storage tank or a pipeline.

StorageTech™ Model 301 Horizontal In-line Deflagration Flame Arrester is intended for pipeline installation close to the source of any potential ignition source by minimising flame speed and the development of an explosive pressure.

The flame quenching element is designed to be three or four times the area of the pipe in which it is installed, and is assembled between two flanged reducing spools.

Flame Arresters are designed to effectively prevent the passage of flame. StorageTech Flame Arresters consist of flame arrester disks made of coiled, corrugated metal strips, spacers and a housing.

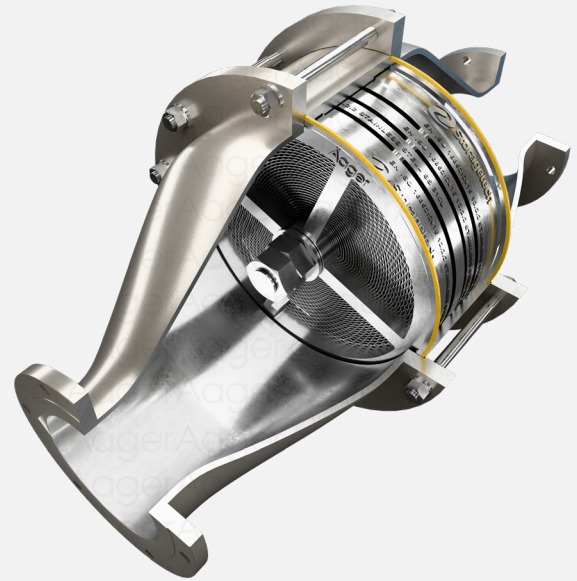

StorageTech provides the high quality and reliable solutions for your needs with 40 years of experience.

Your investments will be much safer with StorageTech™ Flame Arrester solutions, which are completely produced in accordance with international norms.

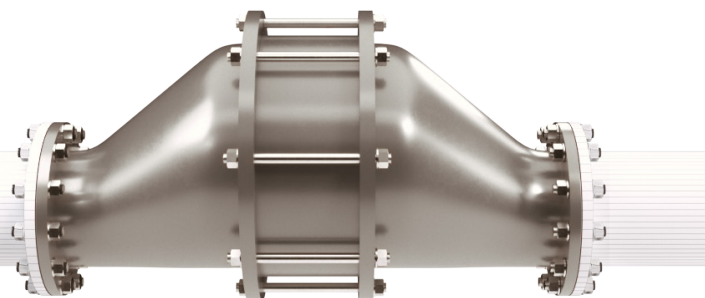

<b>Standard Sizes</b>	2" to 16"(IIA) / 2" to 12"( IIB)
<b>Body / Flanges</b>	1- Carbon steel 2- Stainless steel AISI 304 -L or 316-L 3- Aluminium 4- Customer Specification
<b>Flange Drilling</b>	ANSI #150, PN10-16, and Special
<b>Flame Element</b>	Stainless steel AISI 304 -L or 316-L
<b>Gasket</b>	Nitrile, Viton, Special
<b>Screen</b>	SS 304
<b>Paint Finish</b>	1- Powder Coating, Colour RAL 9006 2- Epoxy Paint, Colour RAL 9006 3- Customer Specification
<b>ATEX Cert</b>	Ex II 1/2 G IIA , G IIB

## In-Line Horizontal Deflagration Arresters

Flame arresters are designed to inhibit flame propagation in gas piping systems and to protect low pressure tanks containing flammable liquids. Arresters protect low flash point liquids from external sources of heat and ignition, increasing fire protection and safety.

Under normal operation the flame element allows the bi-directional flow of air and flammable vapour, however it introduces additional pressure loss, and this must be considered in the design of the system. If a fire or ignition occurs external to the equipment and ignites the flammable discharge, the flame arrester will quench the leading fire by absorbing and dispersing the heat as it passes through the element.

It is suitable for use with any of StorageTech™ Pressure Relief, and Pressure-Vacuum Valves, and should be installed on the inlet to the Pressure Relief unit.

The Model 301 Deflagration flame arrester is suitable for quenching subsonic flames and should be mounted in the vertical plane, close to the source of any potential ignition.

## Design & Manufacturing Specifications



The size of the vent will be calculated in accordance with API Standard 2000-Venting Atmospheric and Low-Pressure Storage Tanks or other international standards.

## Standard Compliance

In-Line Deflagration Flame Arresters has been type-tested to EN ISO 16852 and approved according to ATEX Directive 2014/34/EU.

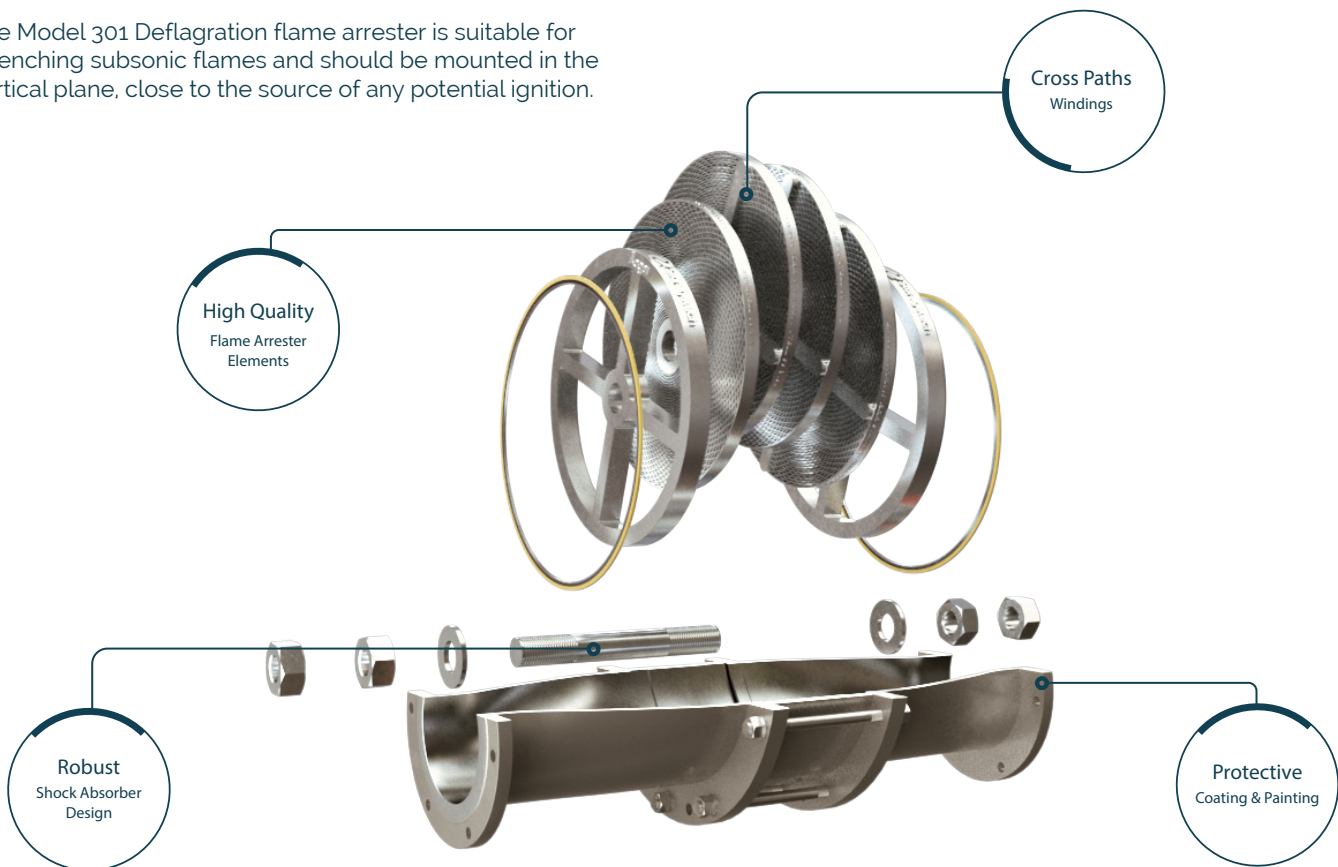

## Key Features

- StorageTech™ PW Model 301 internal materials are AISI 304 or 316 stainless steel.
- Easy to clean internal materials.
- Easy to install. You do not need a special tool or experience to install the StorageTech Flame Arrester Model 301.
- StorageTech™ PVV Model 301 comes with the paint color you choose.
- Standard manufacturing comes with ANSI 150# flange; however other flange types are available on request.
- Protection cap is manufactured from aluminum material.

## Product Benefits

StorageTech™ Flame Arrester Model 301 provides safety. It blocks the flame and does not allow flame travel through a pipeline or any in-out-let. Protects environment. Flame arrester prevents your facility against fire that is caused by explosions.

The area of each passage determines level of protection that the element provides. StorageTech™ Model 301 In-line Deflagration Flame Arrester has a Maximum Experimental Safe Gap as per standard, and is suitable for gas groups IIB and IIA.

Flame arresters are usually designed for use at ambient temperature and pressure. Please consult StorageTech experienced and trained engineers for advice if other conditions are encountered. Higher temperatures and pressures put increased load on the flame arrester and testing under actual or simulated conditions may be required.

Regular inspection and maintenance of flame arresters is essential. If a flashback is known or believed to have occurred then the arrester should be inspected for damage. Small cells or components of the flame arrester are prone to dirt collection and clogging, leading to increased pressure drop. Damaged or dirty elements should be replaced. It is usually possible to clean the element for reuse. When properly maintained, a flame arrester can provide many years of service.

## Unconfined Deflagration

Unconfined deflagration is caused by the ignition of a flammable gas outside a container or equipment. For example, vent gas from a gasoline tank can create a cloud of flammable vapor around it. A lit cigarette, static electricity or lightning can ignite this vapor and the resulting flame can return to the tank.

## Confined Deflagration

When a flammable mixture in a pipeline is ignited, the flame front initially travels along the pipe at subsonic speeds, a phenomenon called confined deflagration. For example, methane gas produced in underground coal mines is transported to the surface through a pipe and burned in a boiler. However, a malfunction in the boiler or pumping system can ignite the gas in the pipe and the flame can travel along the pipe and explode the gas underground.

## Detonation

along a pipe at supersonic speeds and merges with the shock wave. This is usually caused by interruptions in the pipe that create turbulence, such as roughness, bends, valves or cross-sectional changes. It can also occur if the flame is allowed to accelerate a sufficient distance along the pipe. The shock wave is characterized by a change in pressure and density where the flame velocity changes from subsonic to supersonic.



## In-line with Weco Connection Detonation

Depending on the purpose of use in the field, connection types in flame arresters can be provided with hammer unions to meet the needs of pipelines. With these fasteners, which are used in areas where fast plug-in applications are required during operation, the maintenance of flame arresters on the relevant lines can be carried out without requiring any additional connection materials.

The oil and gas sector uses WECO couplings, also known as HAMMER LUG unions, to quickly connect pipes and flexible hose assemblies.

No additional equipment are required to tighten and loosen HAMMER LUG unions—just a hammer, as the name implies.

The components of a HAMMER LUG union are a coupler with an inner cone and a male thread, a ball-shaped fitting with a male half and a female thread nut that secures the ball-shaped fitting to the coupler's cone. Depending on the kind, a primary sealing (metal/metal) is performed by a tight contact of the ball end with the cone, or the sealing is accomplished by a second rubber seal (o-ring or lip seal).

The coupling's (the nut and coupler's) trapezoidal ACME thread is included (standard or modified). They either weld in connections or connect to an installation using NPT female thread end connectors.



The following pertinent industry standards are met or exceeded by all union products: **NACE, ISO, DNV, API, ASTM A-105, ASTM A29, ASTM A536 Grade 65-45-12, and ASME B1.20.1.**

Hammer Unions are used to join heavy-duty, high-pressure flow lines. They may frequently be found in strip mines, chemical factories, maritime dredging vessels, and the oil sector (depending on model, for sand slurry, oil, water, steam, etc).

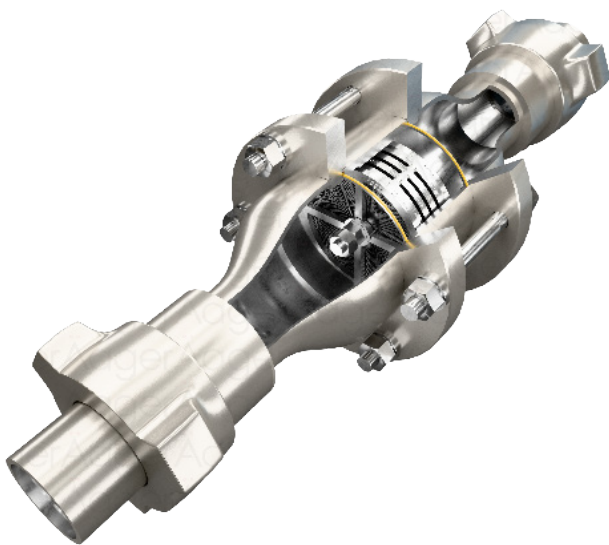

## Technical Drawing

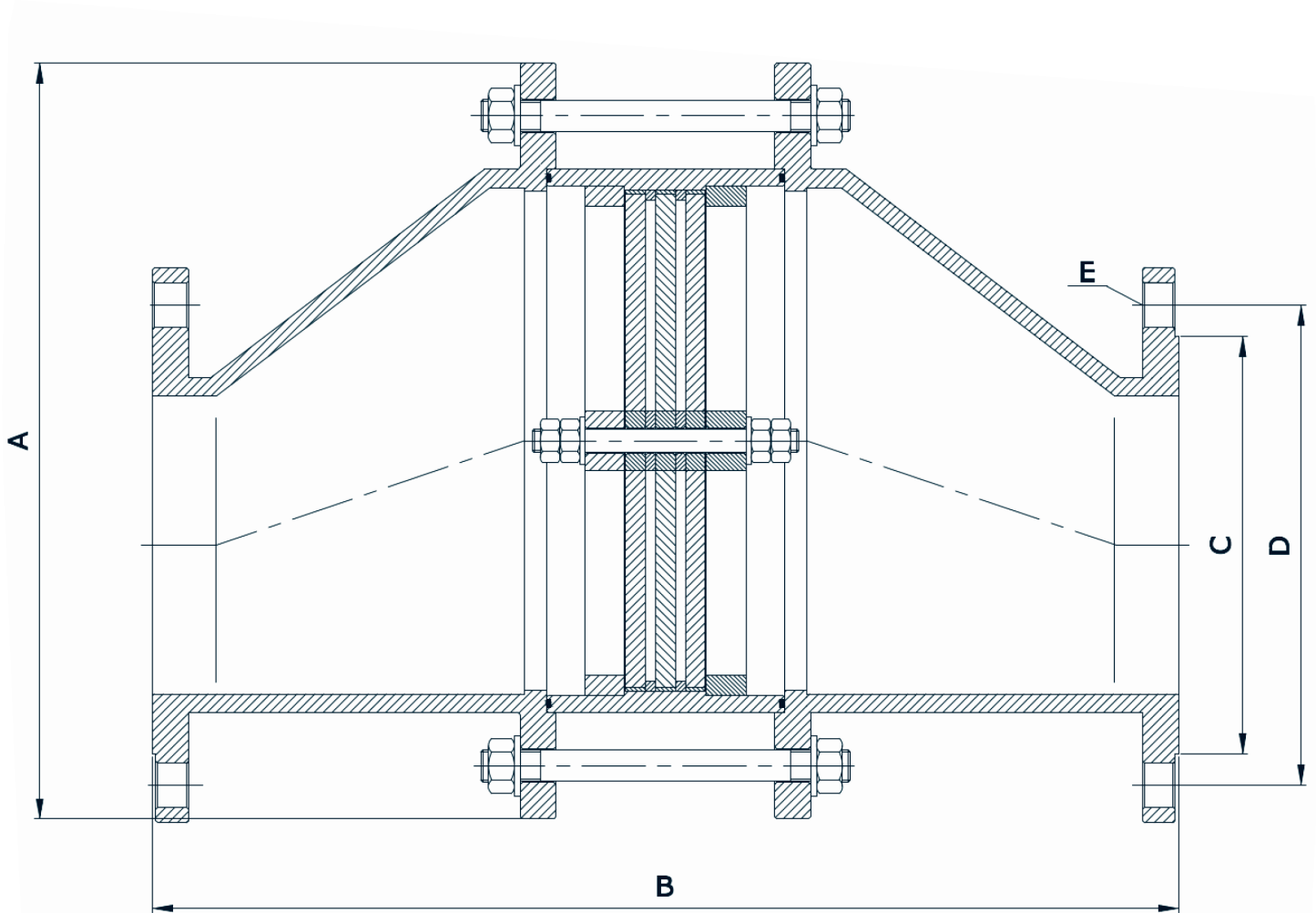

## Weight & Dimensions

SIZE NPS DN	A	B	C	D		E		F		G		TOTAL WEIGHT (kg)				
				ANSI 150# RF	PN 16	ANSI 150# RF	PN 16	ANSI 150# RF	PN 16	ANSI 150# RF	PN 16	WELDED CS	SS	CASTING		
													AL	CS	SS	
2" 50	180	320	18	92	102	120.6	125	152	165	Ø19x4	Ø18x4	15-18	15-18	5-7	15-20	15-20
3" 80	260	396	18	127	138	152.4	160	190	200	Ø19x4	Ø18x8	33-38	33-38	11-14	36-42	36-42
4" 100	315	435	18	157.2	158	190.5	180	229	220	Ø19x8	Ø18x8	45-50	45-50	21-24	46-52	46-52
6" 150	380	516	18	216	212	241.3	240	279	285	Ø22x8	Ø22x8	62-68	62-68	33-37	80-90	80-90
8" 200	455	820	18	270	268	298.4	295	343	340	Ø22x8	Ø22x12	115-125	115-130	46-52	120-140	120-140
10" 250	600	974	22	324	320	362	355	406	405	Ø25.4x12	Ø26x12	165-180	165-185	90-105	215-250	215-250
12" 300	750	750	22	381	378	431.8	410	483	460	Ø25.4x12	Ø26x12	250-280	250-290	165-190	350-390	350-390

MODEL	IIA DEFLAGRATION - MODEL 301									
SIZE	2"	3"	4"	6"	8"	10"	12"	14"	16"	
A	100	150	200	250	300	500	600	700	800	
A-H	10	10	10	10	10	15	15	15	15	
B	100	200	250	280	350	550	700	800	900	
B-H	90	90	90	100	100	200	200	200	200	
C	100	150	200	250	300	500	600	700	800	
C-H	10	10	10	20	20	20	20	20	20	
D	100	150	200	250	300	500	600	700	800	
D-H	6	6	6	6	6	6	6	6	6	

MODEL	IIB DEFLAGRATION - MODEL 301							
SIZE	2"	3"	4"	6"	8"	10"	12"	
A	100	200	250	300	400	500	600	
A-H	30	30	30	30	30	30	30	
B	150	250	300	350	450	550	700	
B-H	*131	151	151	212	232	232	232	
C	100	200	250	300	400	500	600	
C-H	18	28	28	28	38	38	38	

A	•Element Diameter
A-H	•Element Height
B	•Element Housing Diameter
B-H	•Element Housing Height
C	•Element Holder Diameter
C-H	•Element Holder Height
D	•Spacer Diameter
D-H	•Spacer Height

## Flow Capacity Tables

### Pressure Drops (mbar)

Gas Group	Element	Pipe Size	Flow in Nm <sup>3</sup> /h Air																			
			5	10	15	20	30	40	50	60	70	80	90	100	150	200	300	400	500			
IIA	100/10/54	DN50	2"	<0.5	<0.5	<0.5	<0.5	<0.5	<0.5	<0.5	<0.5	<0.5	<0.5	<0.5	0.7	0.9	2.2	3.8	8.8	15.6	26.2	
	150/10/54	DN80	3"	<0.5	<0.5	<0.5	<0.5	<0.5	<0.5	<0.5	<0.5	<0.5	<0.5	<0.5	<0.5	<0.5	0.5	0.8	1.7	2.6	4.8	
	200/10/54	DN100	4"	<0.5	<0.5	<0.5	<0.5	<0.5	<0.5	<0.5	<0.5	<0.5	<0.5	<0.5	<0.5	<0.5	<0.5	<0.5	<0.5	0.7	1.3	
	250/10/54	DN150	6"	<0.5	<0.5	<0.5	<0.5	<0.5	<0.5	<0.5	<0.5	<0.5	<0.5	<0.5	<0.5	<0.5	<0.5	<0.5	<0.5	<0.5	<0.5	
	300/10/54	DN200	8"	<0.5	<0.5	<0.5	<0.5	<0.5	<0.5	<0.5	<0.5	<0.5	<0.5	<0.5	<0.5	<0.5	<0.5	<0.5	<0.5	<0.5	<0.5	
	500/15/54	DN250	10"	<0.5	<0.5	<0.5	<0.5	<0.5	<0.5	<0.5	<0.5	<0.5	<0.5	<0.5	<0.5	<0.5	<0.5	<0.5	<0.5	<0.5	<0.5	
	600/15/54	DN300	12"	<0.5	<0.5	<0.5	<0.5	<0.5	<0.5	<0.5	<0.5	<0.5	<0.5	<0.5	<0.5	<0.5	<0.5	<0.5	<0.5	<0.5	<0.5	
IIB	100/30/35	DN50	2"	<0.5	<0.5	<0.5	<0.5	<0.5	<0.5	<0.5	<0.5	0.7	1.1	1.4	1.8	2.3	5.1	9.2	20.3	36.8	58.2	
	200/30/35	DN80	3"	<0.5	<0.5	<0.5	<0.5	<0.5	<0.5	<0.5	<0.5	<0.5	<0.5	<0.5	<0.5	<0.5	0.5	1.1	2.8	5.2	7.4	
	250/30/35	DN100	4"	<0.5	<0.5	<0.5	<0.5	<0.5	<0.5	<0.5	<0.5	<0.5	<0.5	<0.5	<0.5	<0.5	<0.5	<0.5	<0.5	0.9	1.9	3.2
	300/30/35	DN150	6"	<0.5	<0.5	<0.5	<0.5	<0.5	<0.5	<0.5	<0.5	<0.5	<0.5	<0.5	<0.5	<0.5	<0.5	<0.5	<0.5	<0.5	0.7	1.2
	400/30/35	DN200	8"	<0.5	<0.5	<0.5	<0.5	<0.5	<0.5	<0.5	<0.5	<0.5	<0.5	<0.5	<0.5	<0.5	<0.5	<0.5	<0.5	<0.5	<0.5	<0.5
	500/30/35	DN250	10"	<0.5	<0.5	<0.5	<0.5	<0.5	<0.5	<0.5	<0.5	<0.5	<0.5	<0.5	<0.5	<0.5	<0.5	<0.5	<0.5	<0.5	<0.5	<0.5
	600/30/35	DN300	12"	<0.5	<0.5	<0.5	<0.5	<0.5	<0.5	<0.5	<0.5	<0.5	<0.5	<0.5	<0.5	<0.5	<0.5	<0.5	<0.5	<0.5	<0.5	<0.5

Gas Group	Element	Pipe Size	Flow in Nm <sup>3</sup> /h Air																		
			600	700	800	900	1000	2000	3000	4000	5000	6000	7000	8000	9000	10000	12000	16000	18000		
IIA	100/10/54	DN50	2"	39.3	51.2	68.5	85.2	106.8													
	150/10/54	DN80	3"	7.1	9.2	12.2	15.9	19.2	79.3	189.4											
	200/10/54	DN100	4"	1.8	2.9	3.4	4.1	5.2	20.9	48.3	86.5	139.2									
	250/10/54	DN150	6"	0.7	0.9	1.2	1.5	2.2	7.1	16.8	30.1	45.8	76.9	93.2	123.5	157.1	197.3				
	300/10/54	DN200	8"	<0.5	<0.5	0.5	0.8	1.1	3.9	9.2	15.5	25.1	36.3	49.7	65.2	83.3	103.5	151.4			
	500/15/54	DN250	10"	<0.5	<0.5	<0.5	<0.5	<0.5	0.7	1.9	2.7	5.3	7.4	9.2	12.5	15.3	19.2	27.8	49.4	63.8	
	600/15/54	DN300	12"	<0.5	<0.5	<0.5	<0.5	<0.5	<0.5	0.8	1.4	2.3	3.4	4.9	6.2	7.1	8.7	13.2	24.4	30.2	
IIB	100/10/54	DN50	2"	83.7	115.3	151.5	195.4	245.6													
	150/10/54	DN80	3"	10.1	14.2	18.6	23.2	29.5	118.2												
	200/10/54	DN100	4"	3.9	5.1	7.2	8.8	11.3	45.5	103.2	188.4										
	300/30/35	DN150	6"	1.8	2.3	3.3	4.1	5.4	20.1	45.2	80.3	128.5	187.6								
	400/30/35	DN200	8"	<0.5	0.7	1.3	1.6	2.3	8.2	17.4	30.8	49.3	71.3	97.6	128.2	165.3	206.4				
	500/30/35	DN250	10"	<0.5	<0.5	<0.5	<0.5	0.6	2.8	6.2	11.3	17.5	24.3	32.7	42.6	55.5	68.1	99.3	181.9	234.2	
	600/30/35	DN300	12"	<0.5	<0.5	<0.5	<0.5	<0.5	1.1	3.2	4.7	8.2	11.3	15.4	20.3	25.5	31.1	45.2	81.6	104.3	

# Technical Drawing

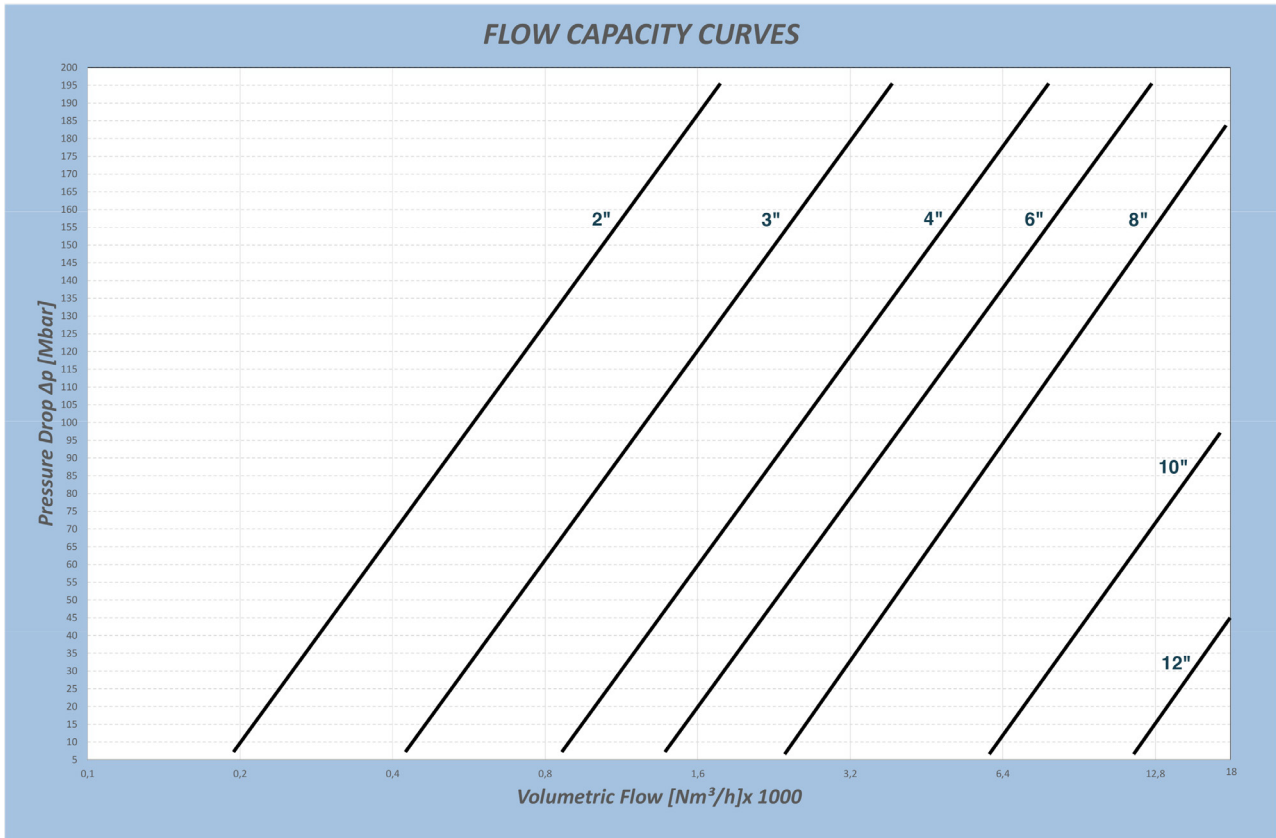

In Line Def. 2A

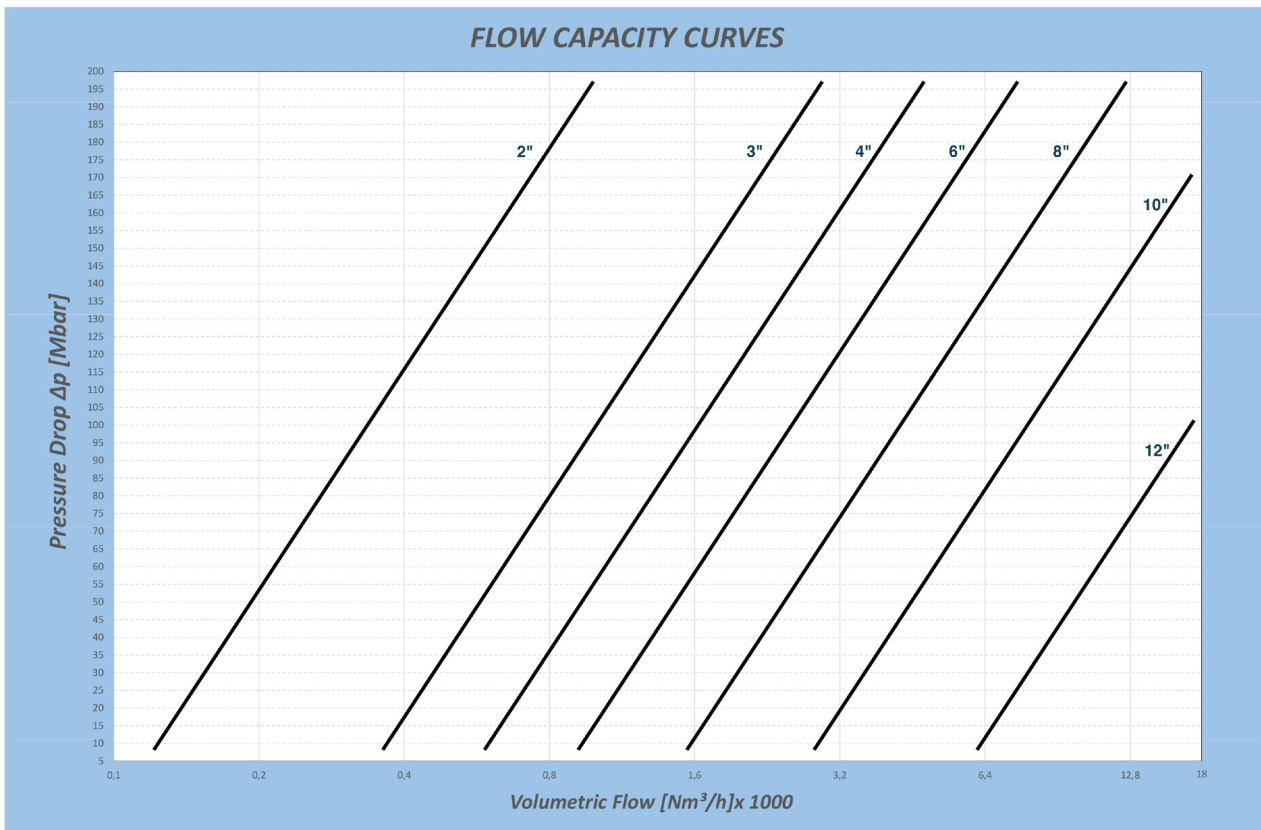

In Line Def. 2B

# Product Recommendations



## Biogas Safety Selector Valve (SSV)

Model: 250

The Storagetech Biogas Safety Selector Valve (SSV) is an advanced, cost-effective alternative to traditional three-way plug valves, designed for seamless operation in biogas systems. It enables smooth switching between Pressure and Vacuum Relief Valves (PVRs) with Flame Arresters, ensuring uninterrupted operation during maintenance.



## Pressure Vacuum Relief Valve With Flame Arrester

End-Of-Line,  
Weight Loaded,  
Combination,  
Atmospheric Deflagration  
Proof

Model: 300

Storagetech™'s Model 300 Pressure Vacuum Relief Valve with Flame Arrester provides protection to bulk storage tanks and vessels from over and under pressurization.

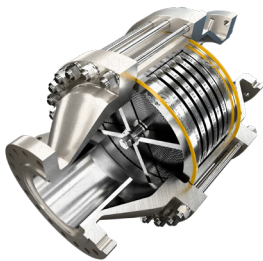

## Flame Arrester

Vertical,  
In-Line,  
Detonation

Model: 320

Storagetech™'s Model 320 In-line Detonation Flame Arrester (also called flame arrester or fire arrester) is designed for installation in gas pipelines. Detonation occurs when a flame travelling through the pipeline reaches supersonic velocities, usually as a result of the pipeline configuration or pipeline surface roughness. Changes in gas density and pressure causes the flame velocity to metamorphose from subsonic to supersonic.



## Flame Arrester

Horizontal,  
In-Line,  
Detonation

Model: 321

Storagetech™'s Model 321 In-line Detonation Flame Arrester (also called flame arrester or fire arrester) is designed for installation in gas pipelines. Detonation occurs when a flame travelling through the pipeline reaches supersonic velocities, usually as a result of the pipeline configuration or pipeline surface roughness. Changes in gas density and pressure causes the flame velocity to metamorphose from subsonic to supersonic.

## Äger GmbH

Germany Head Office + R&D + Sales  
Herzogspitalstraße 24  
Munich 80331  
Germany  
+49 (0) 89 1250 15240  
www.aager.de  
sales@aager.de

Turkey Head Office + Sales  
Ağaoğlu My Office 212  
No: 3 B Blok /175  
PK 34218 Güneşli – Bağcılar  
Istanbul / Turkey  
+90 212 485 40 07  
+90 212 485 40 42  
sales@aager.de  
sales@storagetech.de

Turkey Factory + Engineering + R&D + Sales  
Mersin Tarsus OSB.13.CD.NO:7  
PK: 33540 Mersin, Turkey  
+90 324 676 44 04  
+90 324 676 44 03  
sales@aager.de  
sales@storagetech.de

UAE Sales + Warehouse  
Jumeirah Lake Towers, X2 Tower 1906  
P.O. Box: 123661 Dubai, UAE  
+971 4 450 8051  
+971 4 450 8041  
sales@storagetech.de

KSA Sales + Warehouse  
Q1-14, The Business Quarter,  
King Faisal Road,  
Al Khalidiyyah Al Janubiyah,  
Dammam, KSA  
+966138163471  
sales@storagetech.de

### data sheet series

Flame Arrester  
Horizontal, in-line, def.

Revision No: 03  
ST-DS-FA.HDT-04.25/V3  
storagetech.de

April 2025

